

Sid Richardson Energy Services
 Pyote, Texas
 (432) 943-3032
 cELL: 432-634-2656
 Fax (432) 389-5800



Revamp By: **JAMES BAILEY**

"CCT" Lube System Warranty
 2 Years Defect in Material
 or Workmanship, 5 Years for Check Valves
 Install Date: ?????

Worthington Cub OF5HU
5.00" STROKE 1000 RPM
Station 144 - Unit # 390

Lubrication System Designed By



3201 West Wall St.
 Midland, TX 79701
 Office: 432.520.6700
 fax: 432.520.6707

LUBRICATION DIVISION

Visit Us On The Web: cct.nu

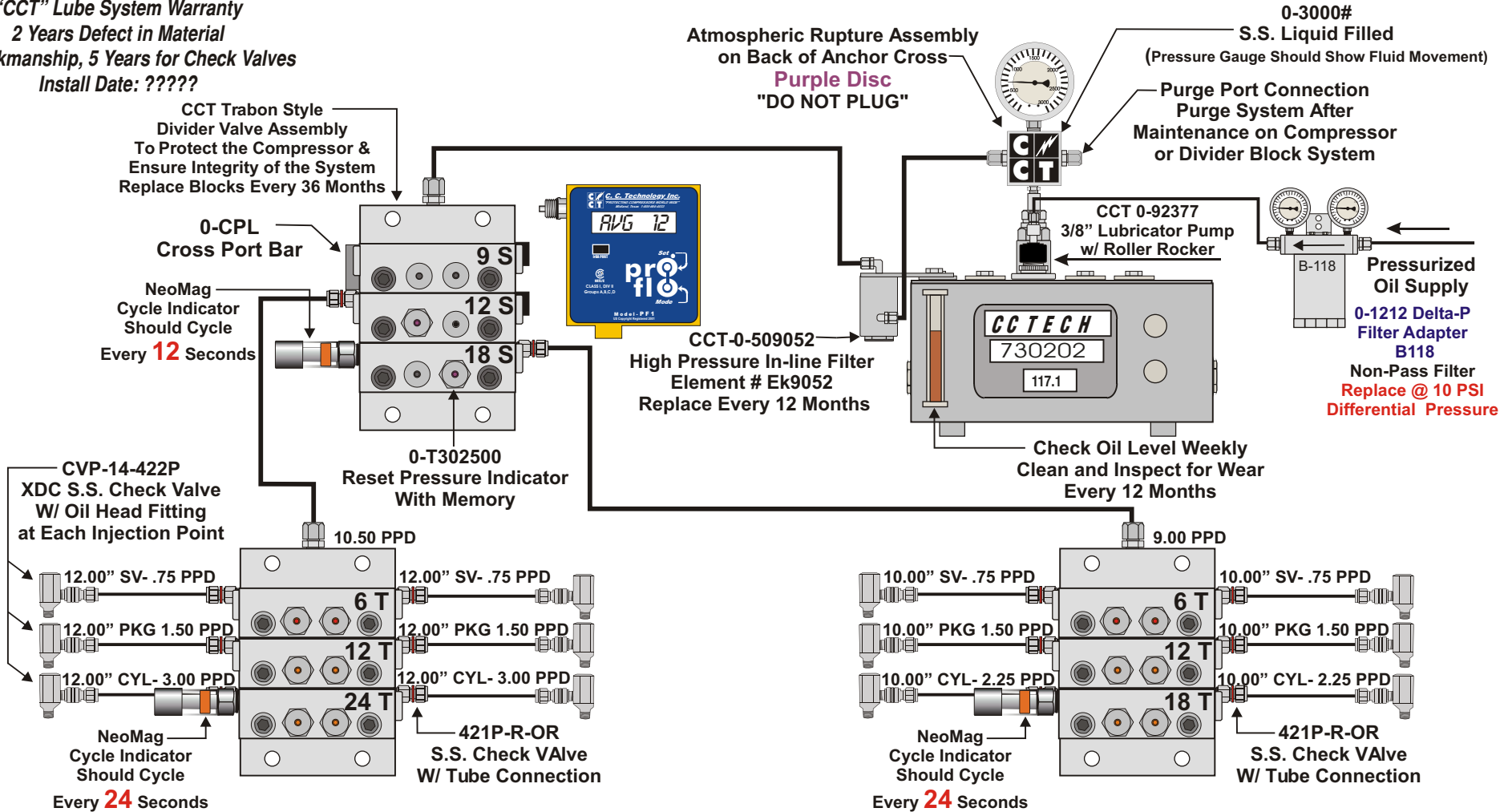

19.50 Pints Per Day
 Master Divider Block Should Cycle
 Once Every **12** Seconds For Recommended Oil Consumption
Overhaul Break-in Cycle Time 6 Seconds for 200 Hours

Drawings & Specifications Are Property of
"CC TECHNOLOGY, INC."
 Reproduction or Use Without
 Written Permission Constitutes Fraud