

Carrera Gas Company, LLC
 Madill Gas Plant Madill, OK
 Revamp By: Alan Higg

580-795-7396 Fax: 580-795-5961
 Divider Block System Warranty: 2 Years
 Check Valve Warranty: 5 Years
 Install Date: 0-00-05

UNIT # CM7
WHITE SUPERIOR MW 76
7.00" STROKE - 900 RPM

Lubrication System Designed By



3201 West Wall St.
 Midland, TX 79701
 Office: 432.520.6700
 fax: 432.520.6707

LUBRICATION DIVISION

Visit Us On The Web: cct.nu

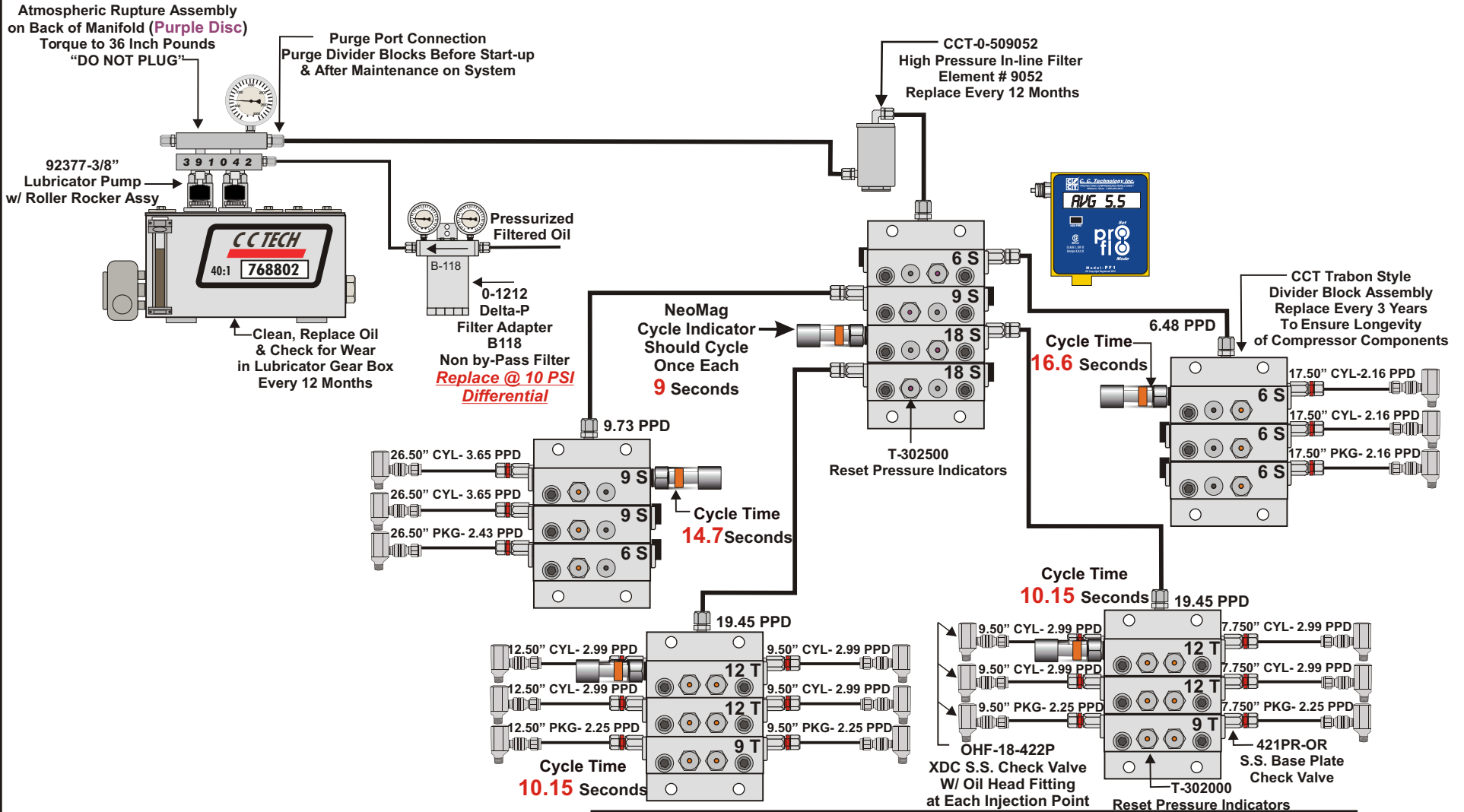

Drawings & Specifications
 Property of "CC TECHNOLOGY, INC."
 Reproduction or Use Without
 Written Permission is Strictly Prohibited

55.11 Pints Per Day @ Rated RPM
proflo Should Display **AVG 5.5 Seconds on LCD**
For Recommended Oil Consumption
Overhaul Break-in Cycle Time **3 Seconds for 200 Hours**