



**BP America Inc.**  
**Block 31 Plant**  
**(432) 558-4833**  
**FAX. (432) 558-4859**  
**Revamp By: Randy Lewis**  
**Jim Schaffer**

# CLARK HBA-8 -1760 HP

## 17" STROKE 300 RPM

### UNIT # K10G

Lubrication System Designed By



**3201 West Wall St.**  
**Midland, TX 79701**  
**Office: 432.520.6700**  
**fax: 432.520.6707**

**LUBRICATION DIVISION**

**Visit Us On The Web: [cct.nu](http://cct.nu)**

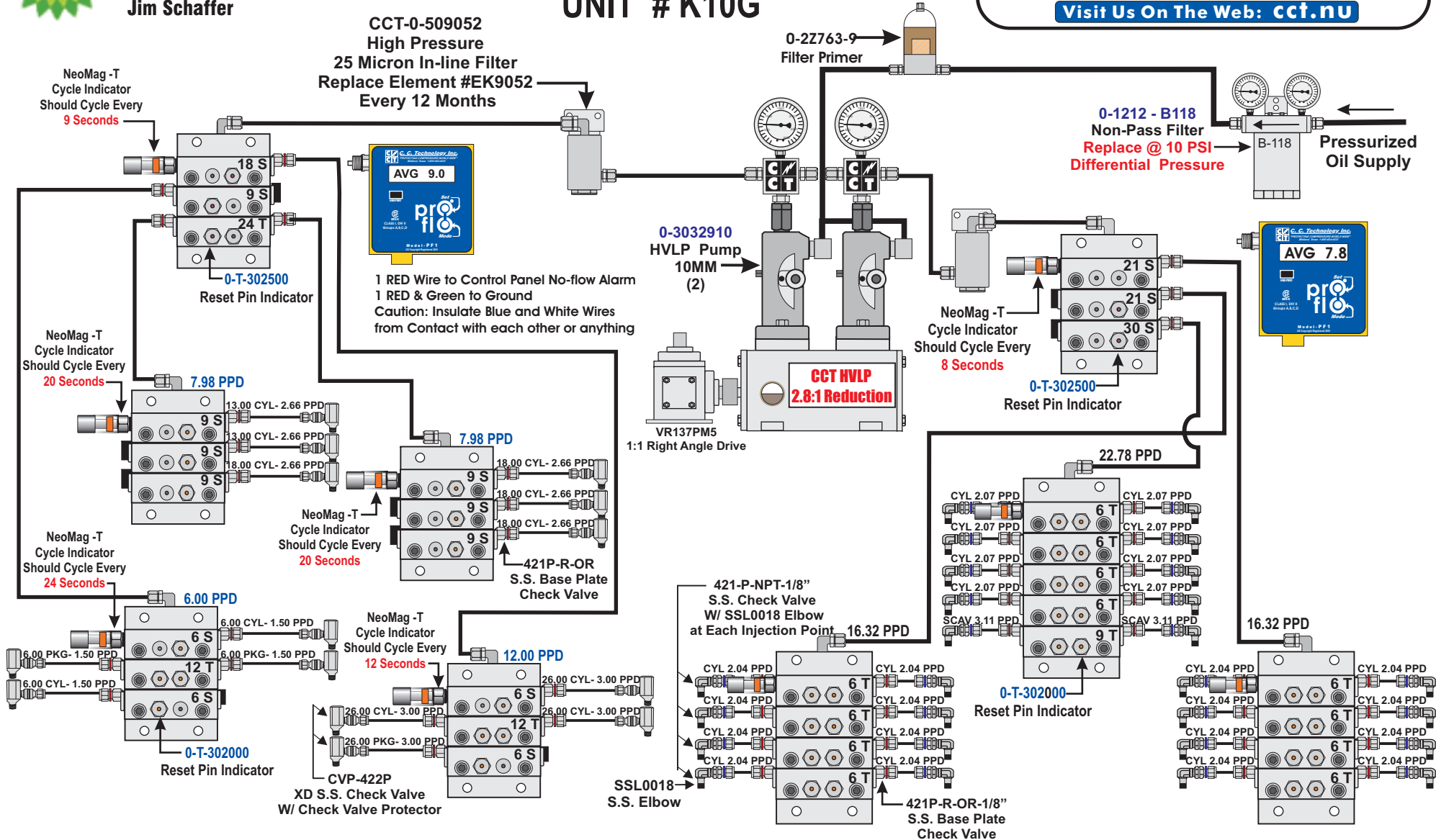

**COMPRESSOR CYLINDERS 33.96 PINTS PER 24 HRS.**  
**LCD Should Display AVG 9 Seconds**  
**For Recommended Oil Consumption**  
**Overhaul Break-in Rates 4.5 Seconds for 200 Hrs**

**Drawings & Specifications are Copyright**  
**Property of "C C TECHNOLOGY INC."**  
**Reproduction or Use Without**  
**Written Permission is Strictly Prohibited**

**POWER CYLINDERS 55.42 PINTS PER 24 HRS.**  
**LCD Should Display AVG 7.8 Seconds**  
**For Recommended Oil Consumption**  
**Overhaul Break-in Rates 4 Seconds For 200 Hrs**