



2404 Commerce Drive, Midland, TX 79703
 432-697-2292 Fax: 432-697-2310
 Revamp By: David Latch
 Mike Powell
 575-369-9772 (Cellular)

proflo LUBRICATION SYSTEM
 "Protecting Compressors World Wide"
 TU-106 AC-19L
 640 RPM MAX (665 RPM Actual)
 H2S- @ 40 PSI MAX

Lubrication System Designed By



3201 West Wall St.
 Midland, TX 79701
 Office: 432.520.6700
 fax: 432.520.6707

LUBRICATION DIVISION

Visit Us On The Web: cct.nu

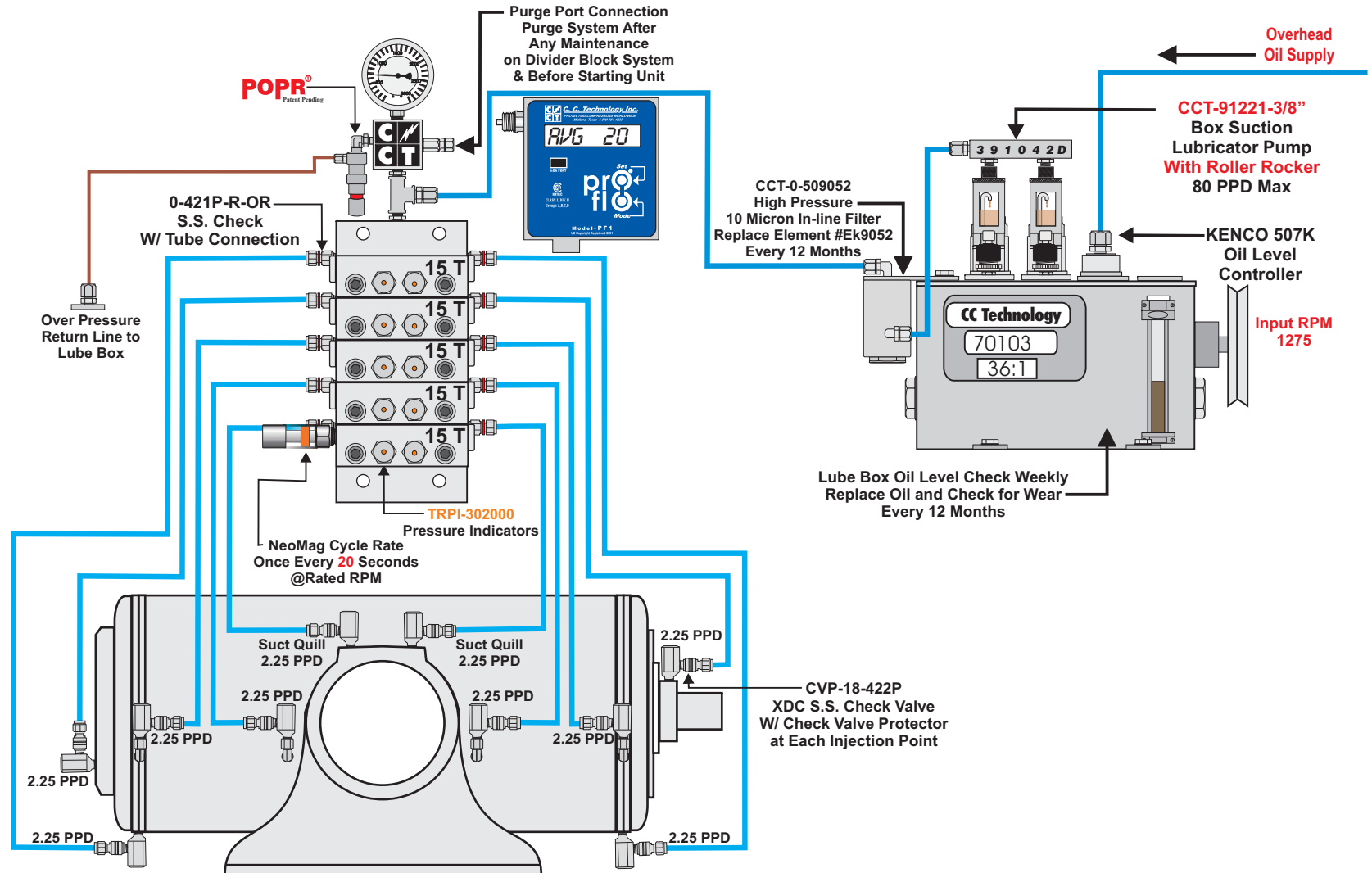

Drawings and Specifications Are Property Of C C Technology Inc. And Shall Not be Duplicated or Used Without Written Permission

22.5 Pints Per Day @ Rated RPM
LCD Should Display AVG 20 Sec. For Recommended Lube Rates
Overhaul Break-in Cycle Time 10 Seconds for 300 Hours