



LUBRICATION DIVISION

Visit Us On the Internet: www.cct.nu

**CCT,
SB & LUBRIQUIP / TRABON*
Divider Block and Baseplate**

O-Ring Installation

with Torque Specifications

Series "HP-CCT & MH-Lubriquip"

NOTICE:

Torque Specifications on this document are to be used for the New CCT-HP replacement for Lubriquip & SB divider blocks

Max Pressure w/ 90 Durometer Viton O-Rings 7500 PSI

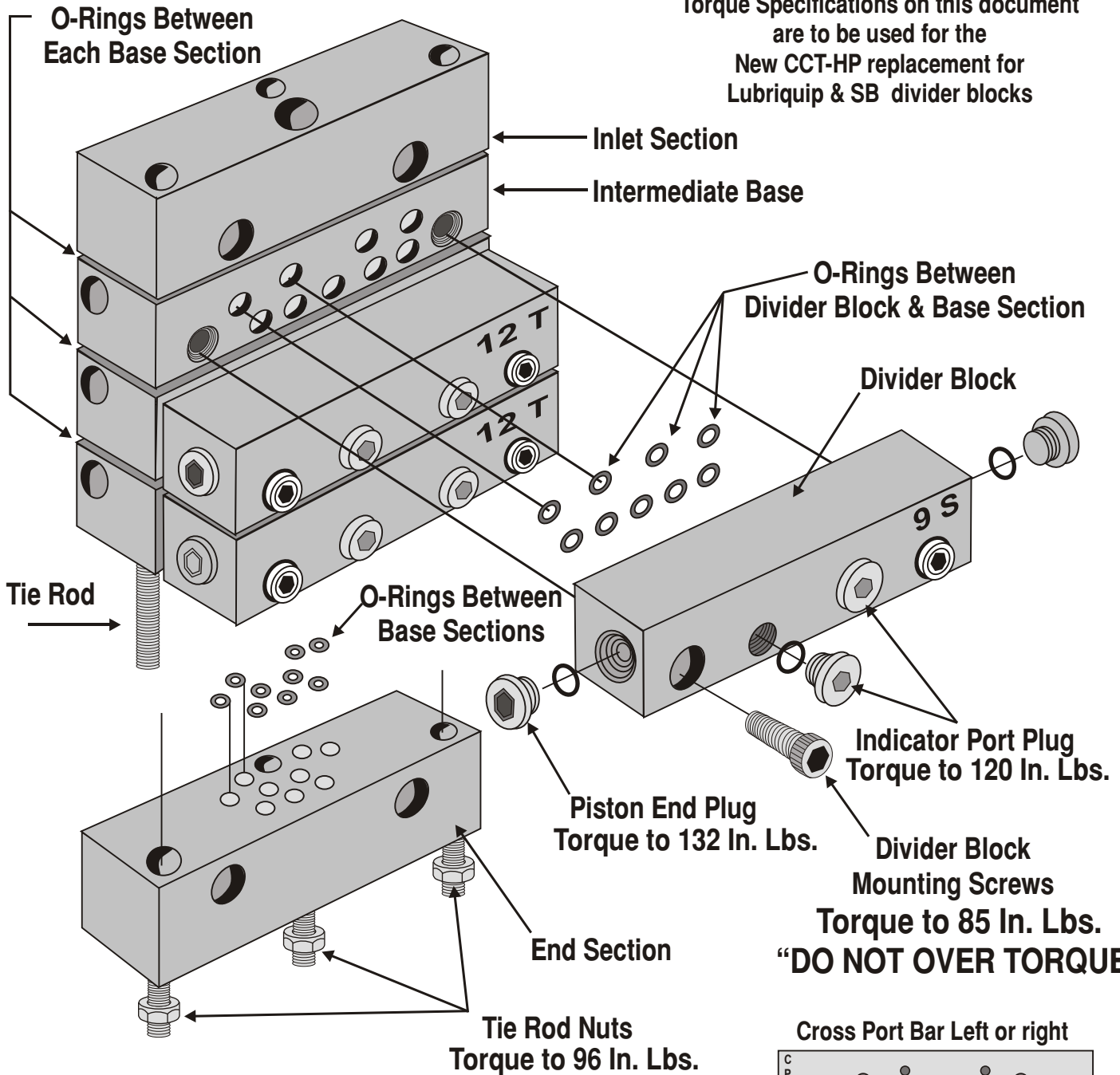

CCT Divider Block Sizes Available

6 - 9 - 12 - 15 - 18 - 21 - 24 - 30

indicating thousandths of a cubic inch displacement



LUBRICATION DIVISION
 Visit Us On the Internet: www.cct.nu

LINCOLN*
Divider Block and Baseplate
Gasket Installation
Series "MC"
"OBSOLETE"

Max Pressure 6000 PSI

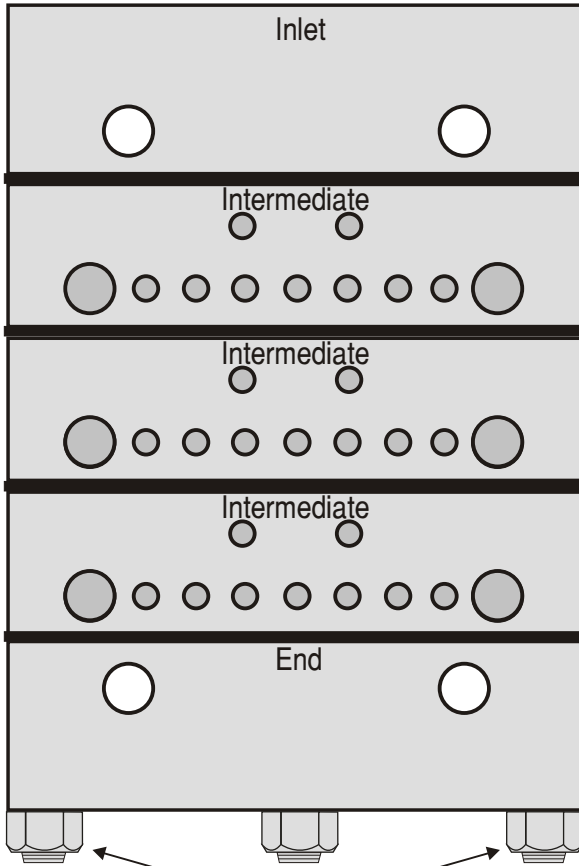

Inlet Gasket Plate
 Install between inlet section and first intermediate baseplate only

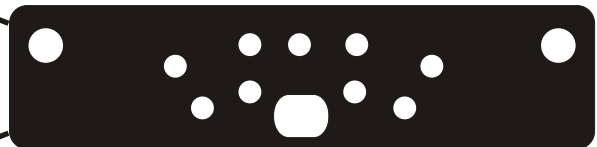

Intermediate Gasket Plate
 Install between intermediate baseplate segments only



End Gasket Plate
 Install between last intermediate baseplate segment and end section only

Torque to 72 In. Lbs.

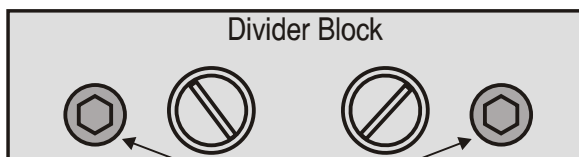

Divider Block Gasket Plate
 Install between divider block and intermediate baseplate segment only

Torque to 108 In. Lbs.



External Combination
 Single / Cross Port Bar
 Part # 87905

Divider Block Sizes Available

6,9,12,18 & 24

indicating thousandths of a cubic inch displacement

Notice: Gasket plates cannot be used on Trabon or SB o-ring seal divider blocks.



LUBRICATION DIVISION

Visit Us On the Internet: www.cct.nu

DropsA* Made in Italy Divider Block and Baseplate O-Ring Installation & Torque Specifications Modular "SMX"

Max Operating Pressure
7200 PSI

Divider Block Sizes Available	
Cubic Centimeters	Cubic Inches
.08	.005
.12	.0075
.16	.010
.25	.015
.35	.021
.40	.025
.50	.030
.60	.036
.65	.040

